

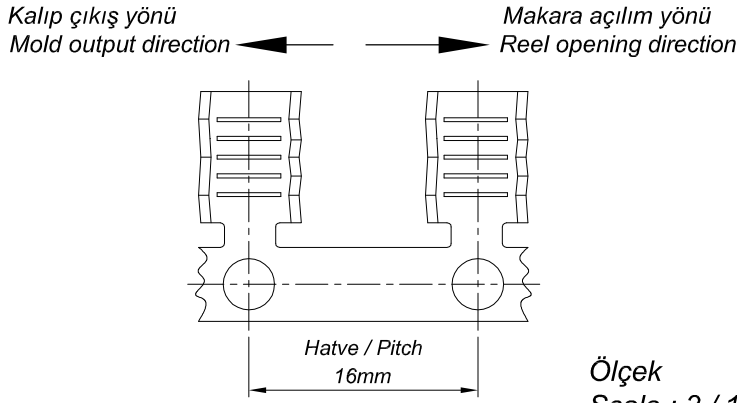

Bu çizim MESA OTO ELEKTRİK LTD.ŞTİ'nin malıdır. Şirket Yetkilerinin izni olmaksızın kopya edilemez, üzerinde değişiklik yapılamaz.
This Drawing MESA AUTO ELECTRIC LTD 's are property. Can not be copied without the consent of the company authorized, any changes can be made.

| PARÇA KODU PART CODE | PARÇA ADI PART NAME | s ÖLÇÜSÜ (KALINLIK) s MEASURE (THICKNESS) | Malzeme Material | Kaplama / Coating | | |
|-------------------------|------------------------|--|-------------------------|-------------------|----|----|
| | | | | SN | AG | Nİ |
| TEK 2858 RP | TIRTILLI EK UCU =RP= | ----- | (CuZn30) Pirinç / Brass | - | - | - |
| TEK 2858 RPK | TIRTILLI EK UCU =RPK= | ----- | (CuZn30) Pirinç / Brass | + | - | - |

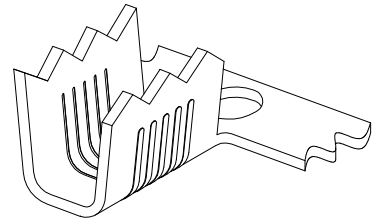
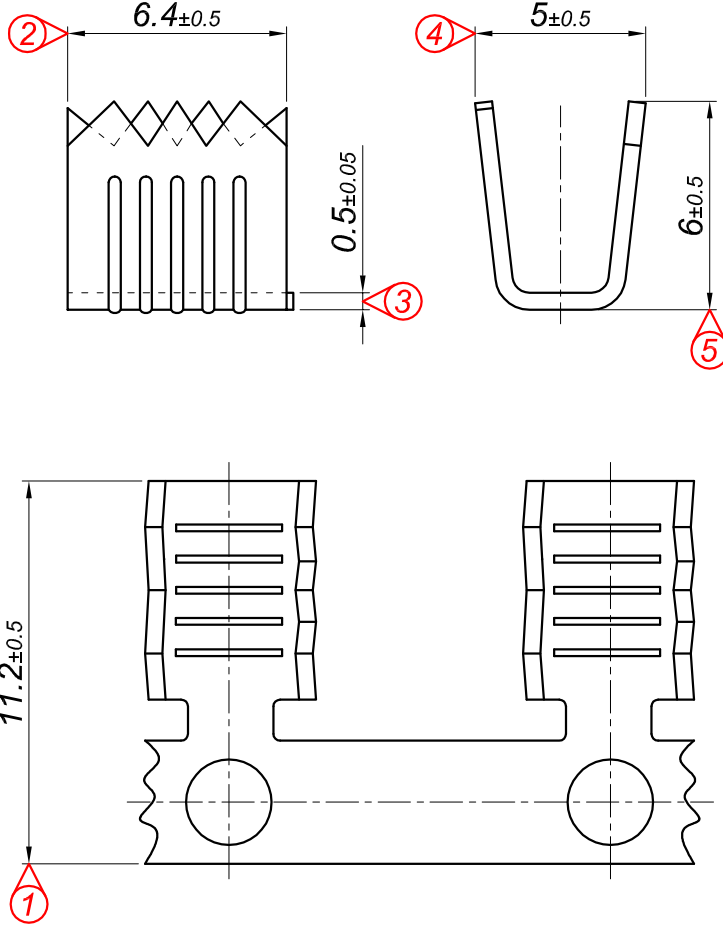

Kablo Kesiti
Wire Section : 1 - 2 mm²

Resmin Üzerinden Ölçü Almayınız
Don't use the drawing for measuring purpose

| | | | | | |
|---|-------------------------|-----------------|--------------------------|-----------------------|------------|
| Tarih / Date | 07.11.2013 | İmza /Signature | Ölçek / Scale | | |
| Çizen / Desing | M.Yağcı | | 5 / 1 | | |
| Onay / Approval | S.Gölcük | | No | Değişiklik / Revision | Tarih/Date |
|  | Parça Adı: Part Name | TIRTILLI EK UCU | Parça Kodu: Part Code | TEK 2858 | |